

Series TY-B, 5.6 K-factor Upright, Pendent, and Recessed Pendent Sprinklers Standard Response, Standard Coverage

General Description

The TYCO Series TY-B, 5.6 K-factor, Upright (TY315) and Pendent (TY325) Sprinklers described in this data sheet are standard response, standard coverage, decorative 5 mm glass bulb type spray sprinklers designed for use in light, ordinary, or extra hazard, commercial occupancies such as banks, hotels, shopping malls, factories, refineries, and chemical plants.

The recessed version of the Series TY-B Pendent Sprinkler, where applicable, is intended for use in areas with a finished ceiling. This recessed pendent sprinkler uses one of the following:

- A two-piece Style 15 Recessed Escutcheon with recessed adjustment up to 5/8 in. (15,9 mm) from the flush pendent position.
- A two-piece Style 20 Recessed Escutcheon with recessed adjustment up to 1/2 in. (12,7 mm) from the flush pendent position.

The adjustment provided by the Recessed Escutcheon reduces the accuracy to which the fixed pipe drops to the sprinklers must be cut.

Intermediate level versions of Series TY-B Sprinklers are described in Technical Data Sheet TFP352. Sprinkler guards and shields are described in Technical Data Sheet TFP780.

IMPORTANT

Refer to Technical Data Sheet TFP2300 for warnings pertaining to regulatory and health information.

Always refer to Technical Data Sheet TFP700 for the "INSTALLER WARNING" that provides cautions with respect to handling and installation of sprinkler systems and components. Improper handling and installation can permanently damage a sprinkler system or its components and cause the sprinkler to fail to operate in a fire situation or cause it to operate prematurely.

NOTICE

The Series TY-B Sprinklers described herein must be installed and maintained in compliance with this document, as well as with the applicable standards of the National Fire Protection Association, in addition to the standards of any other authorities having jurisdiction. Failure to do so may impair the performance of these devices.

The owner is responsible for maintaining their fire protection system and devices in proper operating condition. Contact the installing contractor or product manufacturer with any questions.

Sprinkler Identification Numbers (SINs)

TY315 Upright 5.6K, 1/2 in. NPT
TY325 Pendent 5.6K, 1/2 in. NPT

Technical Data

Approvals

Refer to Table A

Maximum Working Pressure

175 psi (12.1 bar)
250 psi (17.2 bar)*

* The maximum working pressure of 250 psi (17.2 bar) only applies to the listing by Underwriters Laboratories, Inc. (UL).

Discharge Coefficient

K = 5.6 GPM/psi^{1/2} (80,6 LPM/bar^{1/2})

Temperature Ratings

Refer to Table A

Finishes

Sprinkler: Refer to Table B

Recessed Escutcheon: White Coated, Black Coated, Chrome Plated, or Brass Plated

Physical Characteristics

FrameBronze
ButtonBrass/Copper
Sealing AssemblyStainless Steel w/TEFLON
BulbGlass
Compression ScrewBronze
DeflectorBronze

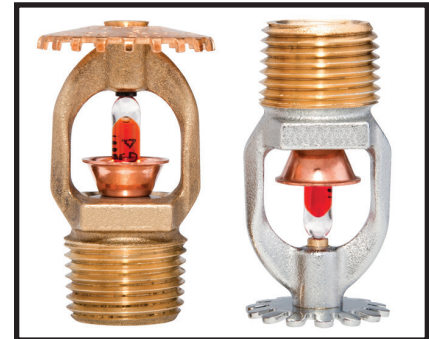

Operation

The glass bulb contains a fluid which expands when exposed to heat. When the rated temperature is reached, the fluid expands sufficiently to shatter the glass bulb, allowing the sprinkler to activate and water to flow.

Design Criteria

The TYCO Series TY-B, 5.6 K-factor, Upright (TY315) and Pendent (TY325) Sprinklers are intended for fire protection systems designed in accordance with the standard installation rules recognized by the applicable Listing or Approval agency (e.g., UL Listing is based on the requirements of NFPA 13, and FM Approval is based on the requirements of the FM Loss Prevention Data Sheets). Only the Style 15 or Style 20 Recessed Escutcheon, as applicable, is to be used for recessed pendent installations.

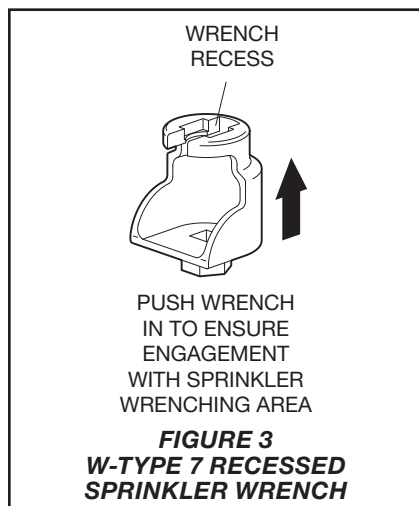
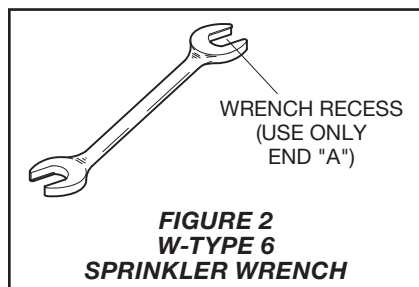
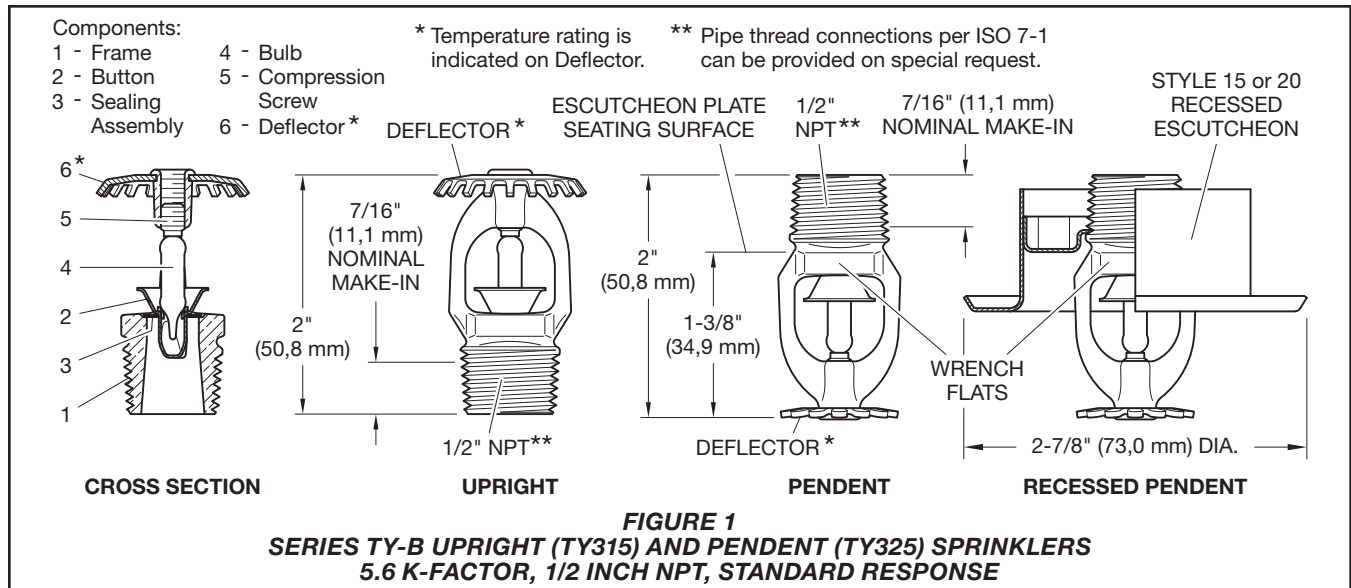

Installation

The TYCO Series TY-B, 5.6 K-factor, Upright (TY315) and Pendent (TY325) Sprinklers must be installed in accordance with this section.

General Instructions

Do not install any bulb type sprinkler if the bulb is cracked or there is a loss of liquid from the bulb. With the sprinkler held horizontally, a small air bubble should be present. The diameter of the air bubble is approximately 1/16 in. (1,6 mm) for the 135°F (57°C) to 3/32 in. (2,4 mm) for the 360°F (182°C) temperature ratings.

A leak-tight 1/2 in. NPT sprinkler joint should be obtained by applying a minimum-to-maximum torque of 7 to 14 lb-ft (9,5 to 19,0 N·m). Higher levels of torque may distort the sprinkler inlet and cause leakage or impairment of the sprinkler.

Do not attempt to compensate for insufficient adjustment in the escutcheon plate by under- or over-tightening the sprinkler. Readjust the position of the sprinkler fitting to suit.

Upright and Pendent Sprinklers

The Series TY-B Upright and Pendent Sprinklers must be installed in accordance with the following instructions.

Step 1. Install pendent sprinklers in the pendent position; install upright sprinklers in the upright position.

Step 2. With pipe-thread sealant applied to the pipe threads, hand-tighten the sprinkler into the sprinkler fitting.

Step 3. Tighten the sprinkler into the sprinkler fitting using only the W-Type 6 Sprinkler Wrench (Figure 2). With reference to Figure 1, apply the W-Type 6 Sprinkler Wrench to the wrench flats. Torque sprinklers 7 to 14 lb-ft (9,5 to 19,0 N·m).

Recessed Pendent Sprinklers

The Series TY-B Recessed Pendent Sprinklers must be installed in accordance with the following instructions.

Step A. After installing the Style 15 or Style 20 Mounting Plate, as applicable, over the sprinkler threads and with pipe-thread sealant applied to the pipe threads, hand-tighten the sprinkler into the sprinkler fitting.

Step B. Tighten the sprinkler into the sprinkler fitting using only the W-Type 7 Recessed Sprinkler Wrench (Figure 3). With reference to Figure 1, apply the W-Type 7 Recessed Sprinkler Wrench to the sprinkler wrench flats. Torque sprinklers 7 to 14 lb-ft (9,5 to 19,0 N·m).

Step C. After the ceiling is installed or the finish coat is applied, slide on the Style 15 or Style 20 Closure over the Series TY-B Sprinkler and push the Closure over the Mounting Plate until its flange contacts the ceiling.

Care and Maintenance

The TYCO Series TY-B, 5.6 K-factor, Upright (TY315) and Pendent (TY325) Sprinklers must be maintained and serviced in accordance with this section.

Before closing a fire protection system main control valve for maintenance work on the fire protection system that it controls, obtain permission to shut down the affected fire protection system from the proper authorities and notify all personnel who may be affected by this action.

Absence of the outer piece of an escutcheon, which is used to cover a clearance hole, can delay sprinkler operation in a fire situation.

The owner must assure that the sprinklers are not used for hanging any objects and that the sprinklers are only cleaned by means of gently dusting with a feather duster; otherwise, non-operation in the event of a fire or inadvertent operation may result.

Sprinklers which are found to be leaking or exhibiting visible signs of corrosion must be replaced.

Automatic sprinklers must never be painted, plated, coated, or otherwise altered after leaving the factory. Modified sprinklers must be replaced. Sprinklers that have been exposed to corrosive products of combustion, but have not operated, should be replaced if they cannot be completely cleaned by wiping the sprinkler with a cloth or by brushing it with a soft bristle brush.

Care must be exercised to avoid damage to the sprinklers before, during, and after installation. Sprinklers damaged by dropping, striking, wrench twist/slippage, or the like, must be replaced. Also, replace any sprinkler that has a cracked bulb or that has lost liquid from its bulb. (Ref. Installation Section.)

Thereafter, annual inspections per NFPA 25 are required; however, instead of inspecting from the floor level, a random sampling of close-up visual inspections should be made.

The owner is responsible for the inspection, testing, and maintenance of their fire protection system and devices in compliance with this document, as well as with the applicable standards of the National Fire Protection Association (e.g., NFPA 25), in addition to the standards of any other authorities having jurisdiction. Contact the installing contractor or product manufacturer with any questions.

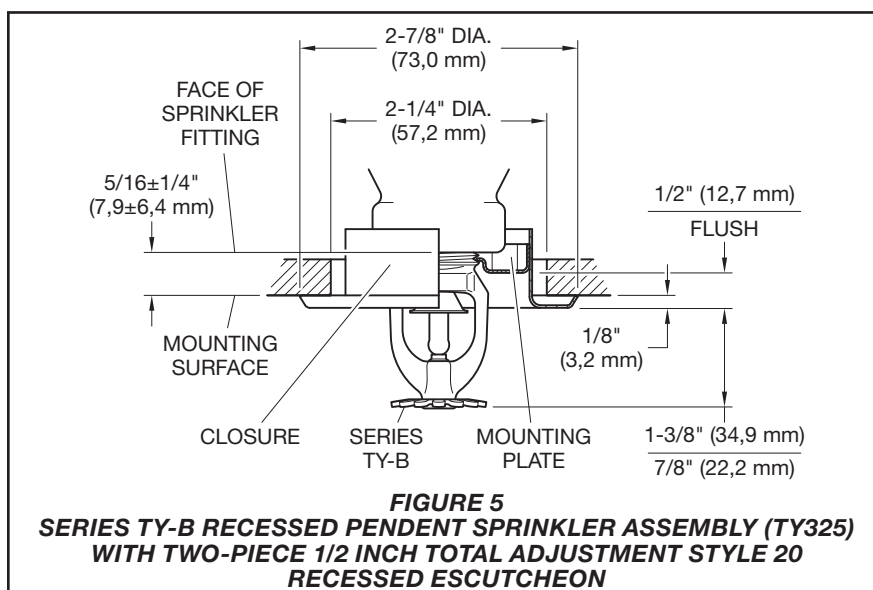
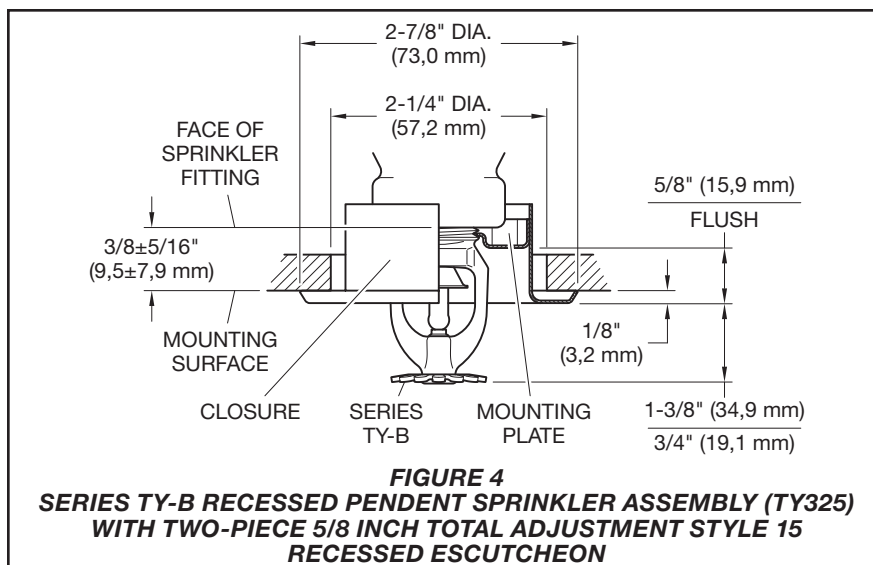

Automatic sprinklers are recommended to be inspected, tested, and maintained by a qualified Inspection Service in accordance with local requirements and/or national codes.

Limited Warranty

For warranty terms and conditions, visit www.tyco-fire.com.

Ordering Procedure

Contact your local distributor for availability. When placing an order, indicate the full product name and Part Number (P/N).

Sprinkler Assemblies with NPT Thread Connections

Specify: Series TY-B Upright or Pendent (specify) Sprinkler, SIN (specify), K=5.6, Standard Response, (specify) temperature rating, (specify) finish, P/N (specify, refer to Table B)

Recessed Escutcheon

Specify: Style 15 Recessed Escutcheon with (specify*) finish, P/N (specify*)
Specify: Style 20 Recessed Escutcheon with (specify*) finish, P/N (specify*)

* Refer to Technical Data Sheet TFP770

Sprinkler Wrench

Specify: W-Type 6 Sprinkler Wrench, P/N 56-000-6-387

Specify: W-Type 7 Sprinkler Wrench, P/N 56-850-4-001

K	SPRINKLER TYPE	TEMPERATURE RATING	BULB LIQUID COLOR	SPRINKLER FINISH (7)		
				NATURAL BRASS	CHROME PLATED	POLYESTER**
5.6 1/2 in. NPT	UPRIGHT (TY315) and PENDENT (TY325) Figure 1	135°F (57°C)	Orange	1, 2, 3, 4, 5, 6,		
		155°F (68°C)	Red			
		175°F (79°C)	Yellow			
		200°F (93°C)	Green			
		286°F (141°C)	Blue			
		360°F (182°C)	Mauve			
	RECESSED PENDENT (TY325)* Figures 4 and 5	135°F (57°C)	Orange	1, 2, 3, 4,		
		155°F (68°C)	Red			
		175°F (79°C)	Yellow			
		200°F (93°C)	Green			
		286°F (141°C)	Blue			

Notes:

- Listed by Underwriters Laboratories, Inc. (UL)
- Listed by Underwriters Laboratories, Inc. for use in Canada (C-UL)
- Approved by FM Global (FM Approvals)
- Approved by the Loss Prevention Certification Board (LPCB Ref. No. 007k/03)
- VdS Approved (For details contact Johnson Controls, Enschede, Netherlands, Tel. 31-53-428-4444 / Fax 31-53-428-3377)
- Approved by the Loss Prevention Certification Board (LPCB Ref. No. 094a/05)
- Where Polyester Coated Sprinklers are noted to be UL and C-UL Listed, the sprinklers are UL and C-UL Listed as Corrosion-Resistant Sprinklers.

* Installed with Style 15 (1/2 in. NPT) 5/8 in. Total Adjustment Recessed Escutcheon, as applicable
** Frame and deflector only
N/A – Not Applicable

TABLE A
SERIES TY-B UPRIGHT AND PENDENT SPRINKLERS
LABORATORY LISTINGS AND APPROVALS

P/N* 77 - XXX - X - XXX

		SIN	SPRINKLER FINISH		TEMPERATURE RATINGS	
570	5.6K UPRIGHT (1/2 in. NPT)	TY315	1	NATURAL BRASS	135	135°F (57°C)
571	5.6K PENDENT (1/2 in. NPT)	TY325	3	PURE WHITE (RAL9010)** POLYESTER	155	155°F (68°C)
			4	SIGNAL WHITE (RAL9003) POLYESTER	175	175°F (79°C)
			5	JET BLACK (RAL9005) POLYESTER	200	200°F (93°C)
			9	CHROME PLATED	286	286°F (141°C)
					360	360°F (182°C)
					000	OPEN***

* Use suffix "I" for ISO 7-1 connection; for example, 77-570-4-175-I
** Eastern Hemisphere sales only
*** OPEN indicates sprinkler assembly without Glass Bulb, Button, and Sealing Assembly

TABLE B
SERIES TY-B UPRIGHT AND PENDENT SPRINKLERS
PART NUMBER SELECTION

Series TY-B – 5.6 K-factor Horizontal and Vertical Sidewall Sprinklers Standard Response, Standard Coverage

General Description

The TYCO Series TY-B, 5.6 K-factor, Horizontal and Vertical Sidewall Sprinklers described in this technical data sheet are standard response, standard coverage decorative 5 mm glass bulb type spray sprinklers designed for use in light and ordinary hazard, commercial occupancies such as banks, hotels, and shopping malls.

They are designed for installation along a wall or the side of a beam and just beneath a smooth ceiling. Sidewall sprinklers are commonly used instead of pendent or upright sprinklers due to aesthetics or building construction considerations, where piping across the ceiling is not desirable.

The recessed version of the Series TY-B Horizontal Sidewall Sprinkler is intended for use in areas with a finished wall. It uses a two-piece Style 10 Recessed Escutcheon. The Recessed Escutcheon provides 1/2 in. (12,7 mm) of recessed adjustment or up to 3/4 in. (19,1 mm) of total adjustment from the flush sidewall position. The adjustment provided by the Recessed Escutcheon reduces the accuracy to which the fixed pipe nipples to the sprinklers must be cut.

Corrosion-resistant coatings, where applicable, are utilized to extend the life of copper alloy sprinklers beyond that which would otherwise be obtained

when exposed to corrosive atmospheres. Although corrosion resistant coated sprinklers have passed the standard corrosion tests of the applicable approval agencies, the testing is not representative of all possible corrosive atmospheres. Consequently, it is recommended that the end user be consulted with respect to the suitability of these coatings for any given corrosive environment. The effects of ambient temperature, concentration of chemicals, and gas/chemical velocity, should be considered, as a minimum, along with the corrosive nature of the chemical to which the sprinklers will be exposed.

NOTICE

The Series TY-B Sprinklers described herein must be installed and maintained in compliance with this document, as well as with the applicable standards of the National Fire Protection Association, in addition to the standards of any other authorities having jurisdiction. Failure to do so may impair the performance of these devices.

The owner is responsible for maintaining their fire protection system and devices in proper operating condition. Contact the installing contractor or product manufacturer with any questions.

Sprinkler Identification Numbers

TY3351. Horizontal Sidewall
TY3451. Vertical Sidewall

Technical Data

Approvals
UL and C-UL Listed
FM Approved
LPCB Certified
NYC Approved

(See Table A for complete approval information, including corrosion-resistant status.)

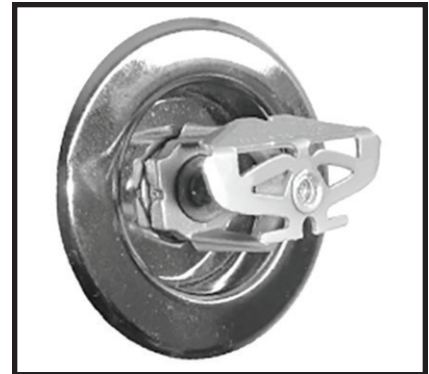

Maximum Working Pressure
See Table B

Discharge Coefficient
K=5.6 gpm/psi^{1/2} (80,6 Lpm/bar^{1/2})

Temperature Ratings
See Table A

Finishes
Sprinkler: See Table C

Recessed Escutcheon: Signal or Pure White, Grey Aluminum, Jet Black, Chrome Plated, or Natural Brass

Physical Characteristics
Frame Bronze
Button Brass/Copper
Sealing Assembly . . Beryllium Nickel w/TEFLON
Bulb Glass
Compression Screw Bronze
HSW Deflector Bronze
VSW Deflector Copper

IMPORTANT

Refer to Technical Data Sheet TFP2300 for warnings pertaining to regulatory and health information.

Always refer to Technical Data Sheet TFP700 for the "INSTALLER WARNING" that provides cautions with respect to handling and installation of sprinkler systems and components. Improper handling and installation can permanently damage a sprinkler system or its components and cause the sprinkler to fail to operate in a fire situation or cause it to operate prematurely.

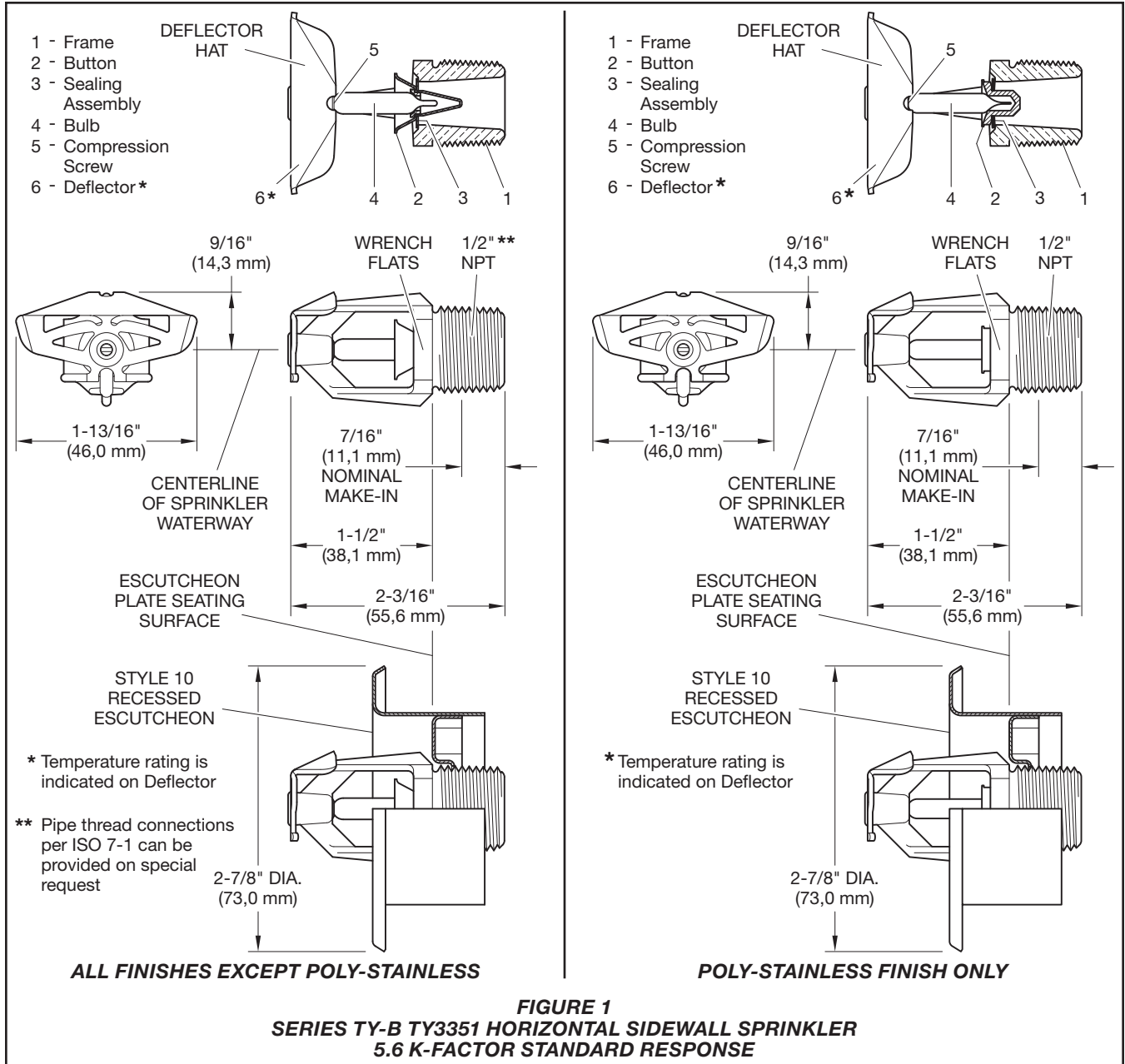

Poly-Stainless
Physical Characteristics

Frame Bronze
Button L316 Stainless Steel*
Bulb Glass
Compression Screw L316 Stainless Steel*
HSW Deflector Copper/Bronze
Sealing Assembly Gold Plated Beryllium Nickel w/TEFLON

*Type L316 stainless steel (UNS 31603) per ASTM A479/479M or BS EN 1008 WN1.4404.

Operation

The glass bulb contains a fluid which expands when exposed to heat. When the rated temperature is reached, the fluid expands sufficiently to shatter the glass bulb, allowing the sprinkler to activate and water to flow.

Design Criteria

The TYCO Series TY-B, 5.6 K-factor, Horizontal and Vertical Sidewall Sprinklers are intended for fire protection systems designed in accordance with the standard installation rules recognized by the applicable Listing or Approval agency (for example, UL Listing is based on the requirements of NFPA 13, and FM Approval is based on the requirements of the FM Loss Prevention Data Sheets). Only the Style 10 Recessed Escutcheon, as applicable, is to be used for recessed horizontal installations.

Installation

The TYCO Series TY-B, 5.6 K-factor, Horizontal and Vertical Sidewall Sprinklers must be installed in accordance with this section.

General Instructions

Do not install any bulb type sprinkler if the bulb is cracked or there is a loss of liquid from the bulb. With the sprinkler held horizontally, a small air bubble should be present. The diameter of the air bubble is approximately 1/16 in. (1,6 mm) for the 135°F (57°C) to 3/32 in. (2,4 mm) for the 360°F (182°C) temperature ratings.

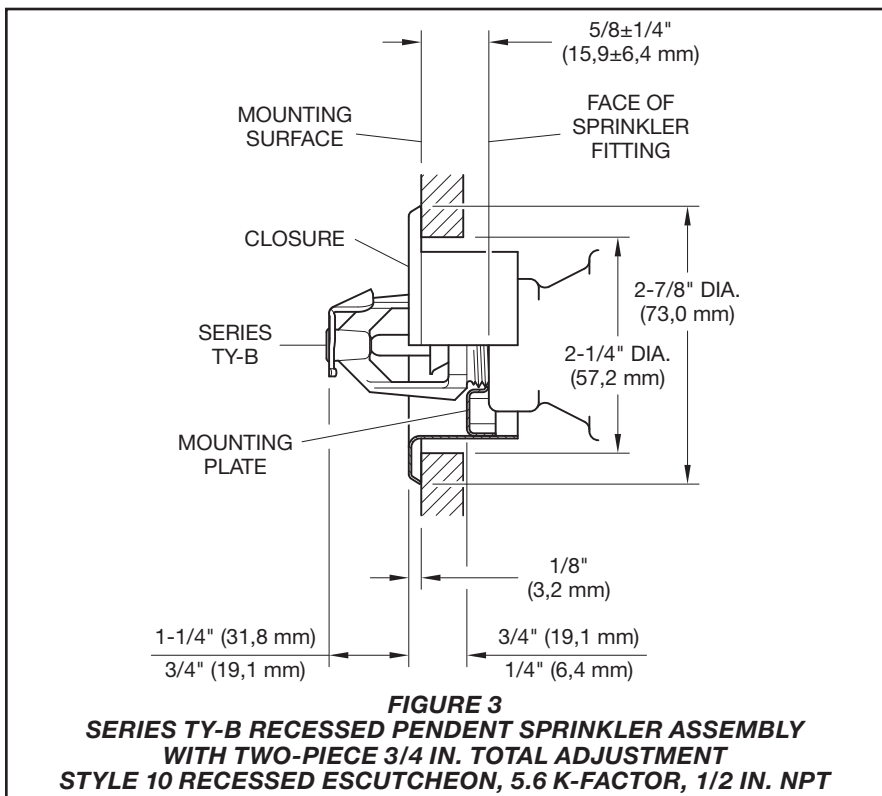
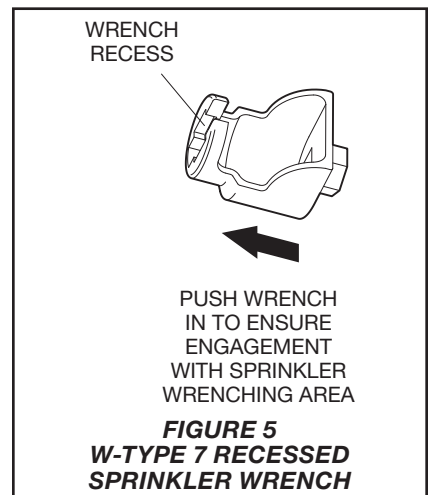
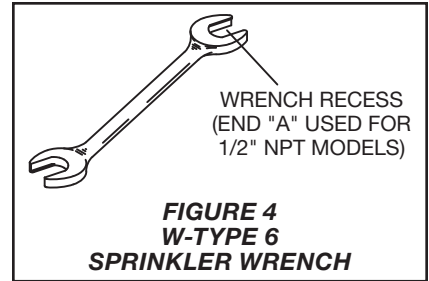
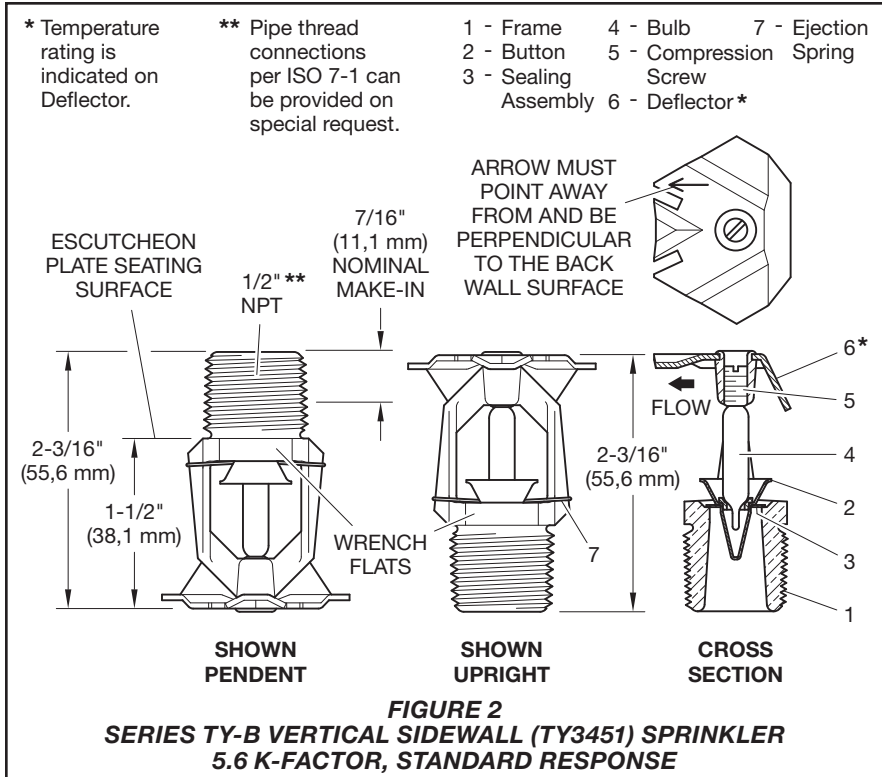

Horizontal Sidewall Sprinkler Installation

The TYCO Series TY-B Recessed Horizontal Sidewall Sprinklers must be installed in accordance with the following instructions. Install recessed horizontal sidewall sprinklers in the horizontal position with the centerline of waterway perpendicular to the back wall and parallel to the ceiling. The word "TOP" on the Deflector is to face towards the ceiling.

Step A. After installing the Style 10 Mounting Plate over the sprinkler threads, hand-tighten the sprinkler into the sprinkler fitting.

Step B. Tighten the sprinkler into the sprinkler fitting using only the W-Type 7 Recessed Sprinkler Wrench, see Figure 5. Apply the W-Type 7 Recessed Sprinkler Wrench to the sprinkler wrench flats, see Figure 1.

Step C. After the ceiling is installed or the finish coat is applied, slide on the Style 10 Closure over the Series TY-B Sprinkler and push the Closure over the Mounting Plate until its flange comes in contact with the ceiling.

A leak-tight 1/2 in. NPT sprinkler joint should be obtained by applying a minimum-to-maximum torque of 7 to 14 lb-ft (9,5 to 19,0 N·m). Higher levels of torque may distort the sprinkler inlet and cause leakage or impairment of the sprinkler. Do not attempt to

make-up for insufficient adjustment in the escutcheon plate by under- or over-tightening the sprinkler. Readjust the position of the sprinkler fitting to suit.

Vertical Sidewall Sprinkler Installation

The Series TY-B Vertical Sidewall Sprinklers must be installed in accordance with the following instructions. Install vertical sidewall sprinklers in the pendent or upright position with the arrow on the Deflector pointing away from the wall.

Step 1. With pipe thread sealant applied to the pipe threads, hand-tighten the sprinkler into the sprinkler fitting.

Step 2. Tighten the sprinkler into the sprinkler fitting using only the W-Type 6 Sprinkler Wrench, see Figure 4. For wax-coated sprinklers, use an 8 or 10 in. adjustable Crescent wrench. Apply the W-Type 6 Sprinkler Wrench or the Crescent wrench, as applicable, to the wrench flats, see Figure 2.

When installing wax-coated sprinklers with the adjustable Crescent wrench, exercise care to prevent damage to the wax coating on the sprinkler wrench flats or frame arms and, consequently, exposure of bare metal to the corrosive environment. Open the jaws of the wrench sufficiently wide to pass over the wrench flats without damaging the wax coating. Before wrench-tightening the sprinkler, adjust the jaws of the wrench to contact only the sprinkler wrench flats. After wrench tightening the sprinkler, loosen the wrench jaws before removing the wrench.

After installation, inspect the sprinkler wrench flats and frame arms and retouch (repair) the wax coating whenever the coating has been damaged and bare metal is exposed. Retouch the wax coating on the wrench flats by gently applying a heated 1/8 in. diameter steel rod to the damaged areas of wax to smooth it back over areas where bare metal is exposed.

NOTICE

Only retouching of the wax coating applied to the wrench flats and frame arms is permitted, and the retouching is to be performed only at the time of the initial sprinkler installation.

The steel rod should be heated only to the point at which it can begin to melt the wax, and appropriate precautions need to be taken when handling the heated rod in order to prevent the installer from being burned.

Care and Maintenance

The TYCO Series TY-B, 5.6 K-factor, Horizontal and Vertical Sidewall Sprinklers must be maintained and serviced in accordance with this section.

Before closing a fire protection system main control valve for maintenance work on the fire protection system that it controls, obtain permission to shut down the affected fire protection system from the proper authorities and notify all personnel who may be affected by this action.

The owner must assure that the sprinklers are not used for hanging any objects and that the sprinklers are only cleaned by means of gently dusting with a feather duster; otherwise, non-operation in the event of a fire or inadvertent operation may result.

Absence of an escutcheon, which is used to cover a clearance, may delay the time to sprinkler operation in a fire situation.

Sprinklers which are found to be leaking or exhibiting visible signs of corrosion must be replaced.

Automatic sprinklers must never be painted, plated, coated, or otherwise altered after leaving the factory. Modified sprinklers must be replaced. Sprinklers that have been exposed to corrosive products of combustion, but have not operated, should be replaced if they cannot be completely cleaned by wiping the sprinkler with a cloth or by brushing it with a soft bristle brush.

Care must be exercised to avoid damage to the sprinklers before, during, and after installation. Sprinklers damaged by dropping, striking, wrench twist/slippage, or the like, must be replaced. Sprinklers that have a cracked bulb or that have lost liquid from its bulb must be replaced, see Installation Section.

The owner is responsible for the inspection, testing, and maintenance of their fire protection system and devices in compliance with this document, as well as with the applicable standards of the National Fire Protection Association, such as, NFPA 25, in addition to the standards of any other authorities having jurisdiction. Contact the installing contractor or product manufacturer with any questions.

Automatic sprinklers are recommended to be inspected, tested, and maintained by a qualified Inspection Service in accordance with local requirements and/or national codes.

K-Factor	Sprinkler Type	Temperature Rating	Bulb Liquid Color	Sprinkler Finish ⁽¹⁰⁾						
				Natural Brass	Chrome Plated	Polyester ^c	Poly-Stainless ^c	Lead Coated	Wax Coated	Wax-Over-Lead Coated
5.6 1/2 in. NPT	Horizontal Sidewall (TY3351) Figure 1	135°F (57°C)	Orange	1, 2, 3, 4, 9		1, 2, 3, 9	1, 2	1, 2, 3, 9	1, 2, 3, 9	
		155°F (68°C)	Red							
		175°F (79°C)	Yellow							
		200°F (93°C)	Green							
		286°F (141°C)	Blue							
		360°F (182°C)	Mauve							1, 2, 4, 9
	Recessed Horizontal Sidewall (TY3351) ^a Figure 3	135°F (57°C)	Orange	1, 2, 3, 9		1, 2	N/A			
		155°F (68°C)	Red							
		175°F (79°C)	Yellow							
		200°F (93°C)	Green							
5.6 1/2 in. NPT	Vertical Sidewall (TY3451) Pendent or Upright Figure 2	135°F (57°C)	Orange	5, 6, 7, 9		N/A	5, 6, 7, 9	5, 6, 7, 9		
		155°F (68°C)	Red							
		175°F (79°C)	Yellow							
		200°F (93°C)	Green							
		286°F (141°C)	Blue							
		360°F (182°C)	Mauve						5, 6, 9	N/A

Notes:

- UL Listed for use in Light and Ordinary Hazard Occupancies at a 4 to 12 in. (100 to 300 mm) top of deflector-to-ceiling distance
 - C-UL Listed for use in Light and Ordinary Hazard Occupancies at a 4 to 12 in. (100 to 300 mm) top of deflector-to-ceiling distance
 - FM Approved for use in Light Hazard Occupancies at a 4 to 12 IN. (100 to 300 mm) top of deflector-to-ceiling distance
 - LPCB Approved (Ref. No. 094a & 007k) at a 4 to 6 in. (100 to 150 mm) deflector-to-ceiling distance
 - UL Listed for use in Light and Ordinary Hazard Occupancies
 - C-UL Listed for use in Light and Ordinary Hazard Occupancies
 - FM Approved for use in Light Hazard Occupancies
 - LPCB Approved (Ref. No. 094a & 007k)
 - Approved by the City of New York under MEA 354-01-E
 - Where Polyester Coated, Lead Coated, Wax Coated, and Wax-over-Lead Coated Sprinklers are noted to be UL and C-UL Listed, the sprinklers are UL and C-UL Listed as corrosion-resistant sprinklers. Where Lead Coated, Wax Coated, and Wax-over-Lead Coated Sprinklers are noted to be FM Approved, the sprinklers are FM Approved as corrosion-resistant sprinklers.
- a. Installed with Style 10 (1/2 in. NPT) or Style 40 (3/4 in. NPT) 3/4 in. Total Adjustment Recessed Escutcheon, as applicable
b. 150°F (66°C) maximum ceiling temperature
c. Frame and deflector only
N/A – Not Applicable

TABLE A
SERIES TY-B 5.6 K-FACTOR HORIZONTAL AND VERTICAL SPRINKLERS
LABORATORY LISTINGS AND APPROVALS

K-Factor	Sprinkler Type	Sprinkler Finish				
		Natural Brass	Chrome Plated	Polyester ¹	Lead Coated	Wax Coated
5.6 1/2 in. NPT	Horizontal Sidewall (TY3351)	250 psi (17,2 bar) ² OR				
	Recessed Horizontal Sidewall (TY3351)	175 psi (12,1 bar)				
	Vertical Sidewall (TY3451)	175 psi (12,1 bar)				

Notes:

- Frame and deflector only
- The maximum working pressure of 250 psi (17,2 bar) only applies to UL Listing, C-UL Listing and Approval by the City of New York

TABLE B
SERIES TY-B 5.6 K-FACTOR HORIZONTAL AND VERTICAL SPRINKLERS
MAXIMUM WORKING PRESSURE

P/N 57 - XXX - X - XXX

		SIN			TEMPERATURE RATING	
578	HORIZONTAL SIDEWALL	TY3351	1	NATURAL BRASS	135	135°F (57°C)
575	VERTICAL SIDEWALL	TY3451	2	POLY-STAINLESS GREY ALUMINUM (RAL9007) ¹ POLYESTER	155	155°F (68°C)
			3	PURE WHITE (RAL9010) ² POLYESTER	175	175°F (79°C)
			4	SIGNAL WHITE (RAL9003) POLYESTER	200	200°F (93°C)
			5	JET BLACK (RAL9005) ³ POLYESTER	286	286°F (141°C)
			6	WAX COATED 286 °F (141 °C) MAX	360	360°F (182°C)
			7	LEAD COATED	000	OPEN ⁴
			8	WAX-OVER-LEAD 286 °F (141 °C) MAX		
			9	CHROME PLATED		

Notes:

1. Available for TY3351 only
2. Eastern Hemisphere sales only
3. Available only for 155 °F (68 °C) or 200 °F (93 °C) temperature rated sprinklers
4. Available only for horizontal sidewall TY3351 for use in Deluge Systems ("OPEN" indicates sprinkler assembly without glass bulb, button, and sealing assembly)

TABLE C
SERIES TY-B HORIZONTAL AND VERTICAL SIDEWALL SPRINKLERS
PART NUMBER SELECTION

Color	Sprinkler Temperature Rating	Part Number
Black	135°F (57°C)	56-065-1-135
Red	155°F (68°C)	56-065-1-155
Yellow	175°F (79°C)	56-065-1-175
Blue	200°F (93°C) 286°F (141°C)	56-065-1-286

TABLE D
SERIES TY-B HORIZONTAL AND VERTICAL SIDEWALL SPRINKLERS
WAX RETOUCHING STICK PART NUMBER SELECTION

Limited Warranty

For warranty terms and conditions, visit www.tyco-fire.com.

Ordering Procedure

Contact your local distributor for availability. When placing an order, indicate the full product name and Part Number (P/N).

Sprinkler Assemblies with NPT Thread Connections

Specify: Series TY-B (specify SIN), (specify K-factor), (specify Horizontal or Vertical Sidewall) Sprinklers with (specify) temperature rating, (specify) finish or coating, P/N (See Table C)

Recessed Escutcheon

Specify: Style 10 Recessed Escutcheon with (specify) finish, P/N (specify*)

* Refer to Technical Data Sheet TFP770

Sprinkler Wrench

Specify: W-Type 6 Sprinkler Wrench, P/N 56-000-6-387

Specify: W-Type 7 Sprinkler Wrench, P/N 56-850-4-001

Wax Sticks

(for retouching wrench-damaged wax coating)

Specify: (specify color, below) Colored Coded Wax Stick for retouching (specify temperature rating) temperature-rated Series TY-B Sprinklers, P/N (specify)

Note: Each wax stick is suitable for retouching up to 25 sprinklers.

Note: The wax used for 286°F (141°C) sprinklers is the same as for 200°F (93°C) sprinklers, and therefore the 286°F (141°C) sprinkler is limited to the same maximum ceiling temperature as the 200°F (93°C) sprinkler, that is 150°F (66°C).

Series TY-B — 5.6 K-factor Conventional (Old Style) Sprinklers Standard Response

General Description

The TYCO Series TY-B, 5.6 K-factor, Conventional Sprinklers (TY365) described in this data sheet are standard response -standard coverage, decorative 5 mm glass bulb type spray sprinklers. These sprinklers are intended to be installed either pendent or upright, and in either position, they produce a spherical water discharge pattern with approximately 50% of the discharge directed upwards and approximately 50% of the discharge directed downwards.

Conventional sprinklers are generally used with Ordinary and Extra High Hazard Class Systems, as defined by the automatic sprinkler system installation rules of the country and authority having jurisdiction. The NFPA permits the use of "Old Style Sprinklers" where special construction features require a unique water distribution; for the protection of fur vaults; or, the replacement of similar sprinklers that had been installed prior to 1955.

NOTICE

The TYCO Series TY-B 5.6 K-factor Conventional Sprinklers described herein must be installed and maintained in compliance with this document, as well as with the applicable standards of the NATIONAL FIRE PROTECTION ASSOCIATION, in addition to

IMPORTANT

Refer to Technical Data Sheet TFP2300 for warnings pertaining to regulatory and health information.

Always refer to Technical Data Sheet TFP700 for the "INSTALLER WARNING" that provides cautions with respect to handling and installation of sprinkler systems and components. Improper handling and installation can permanently damage a sprinkler system or its components and cause the sprinkler to fail to operate in a fire situation or cause it to operate prematurely.

the standards of any other authorities having jurisdiction. Failure to do so may impair the performance of these devices.

The owner is responsible for maintaining their fire protection system and devices in proper operating condition. Contact the installing contractor or product manufacturer with any questions.

Sprinkler Identification Number (SIN)

TY365
TY3650 (LPCB Approved only)

Technical Data

Approvals
Refer to Table A

Maximum Working Pressure
175 psi (12,1 bar)

Discharge Coefficient
K = 5.6 GPM/psi^{1/2} (80,6 LPM/bar^{1/2})

Temperature Ratings
135°F (57°C)
155°F (68°C)
175°F (79°C)
200°F (93°C)
286°F (141°C)
360°F (182°C)

Finishes
Refer to Table B

Physical Characteristics

Frame	Bronze
Button	Brass/Copper
Sealing Assembly	Stainless Steel w/TEFLON
Bulb	Glass
Compression Screw	Bronze
Deflector	Bronze



Operation

The glass bulb contains a fluid which expands when exposed to heat. When the rated temperature is reached, the fluid expands sufficiently to shatter the glass bulb, allowing the sprinkler to activate and water to flow.

Design Criteria

The TYCO Series TY-B, 5.6 K-factor, Conventional Sprinklers (TY365) are intended for fire protection systems designed in accordance with the standard installation rules recognized by the applicable Listing or Approval agency (e.g., UL Listing is based on NFPA 13 requirements). The Series TY-B Conventional Sprinklers are only for non-recessed applications.

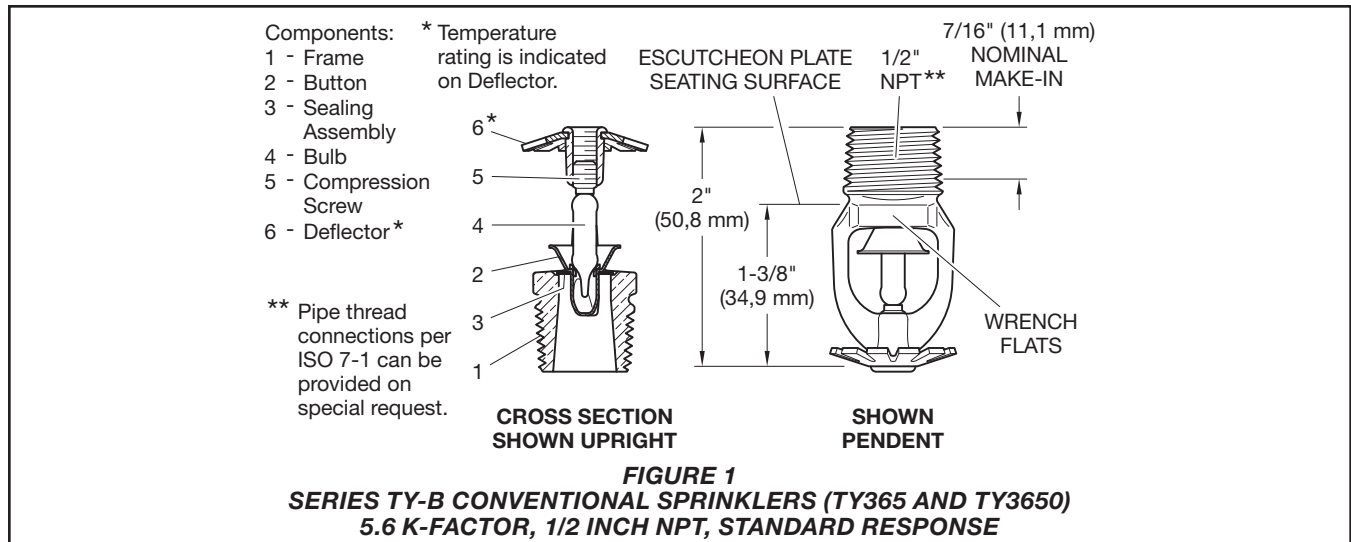

Installation

The TYCO Series TY-B, 5.6 K-factor, Conventional Sprinklers (TY365) must be installed in accordance with this section:

General Instructions

Do not install any bulb type sprinkler if the bulb is cracked or there is a loss of liquid from the bulb. With the sprinkler held horizontally, a small air bubble should be present. The diameter of the air bubble is approximately 1/16 in. (1,6 mm) for the 135°F (57°C) to 3/32 in. (2,4 mm) for the 360°F (182°C) temperature ratings.

A leak tight 1/2 in. NPT sprinkler joint should be obtained with a torque of 7 to 14 lb-ft (9,5 to 19,0 N·m). Higher levels of torque may distort the sprinkler inlet and cause leakage or impairment of the sprinkler.

Step 1. With pipe thread sealant applied to the pipe threads, hand tighten the sprinkler into the sprinkler fitting.

Step 2. Tighten the sprinkler into the sprinkler fitting using only the W-Type 6 Sprinkler Wrench (Figure 2), except that an 8 in. or 10 in. adjustable Crescent wrench is to be used for wax coated sprinklers. With reference to Figure 1, the W-Type 6 Sprinkler Wrench or the Crescent wrench, as applicable, is to be applied to the wrench flats.

Care and Maintenance

The TYCO Series TY-B, 5.6 K-factor, Conventional Sprinklers (TY365) must be maintained and serviced in accordance with this section.

Before closing a fire protection system main control valve for maintenance work on the fire protection system that it controls, obtain permission to shut down the affected fire protection systems from the proper authorities and notify all personnel who may be affected by this action.

Sprinklers which are found to be leaking or exhibiting visible signs of corrosion must be replaced.

Automatic sprinklers must never be painted, plated, coated, or otherwise altered after leaving the factory. Modified sprinklers must be replaced. Sprinklers that have been exposed to corrosive products of combustion, but have not operated, should be replaced if they cannot be completely cleaned by wiping the sprinkler with a cloth or by brushing it with a soft bristle brush.

Care must be exercised to avoid damage to the sprinklers before, during, and after installation. Sprinklers damaged by dropping, striking, wrench twist/slippage, or the like, must be replaced. Also, replace any sprinkler that has a cracked bulb or that has lost liquid from its bulb. Refer to the Installation section for additional information.

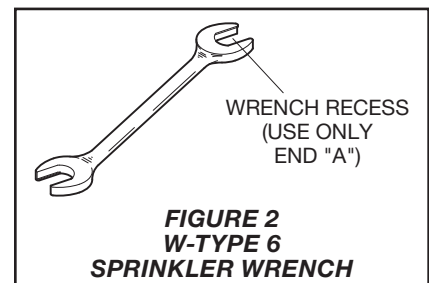

The owner is responsible for the inspection, testing, and maintenance of their fire protection system and devices in compliance with this document, as well as with the applicable standards of the NATIONAL FIRE PROTECTION ASSOCIATION (e.g., NFPA 25), in addition to the standards of any other authorities having jurisdiction. Contact the installing contractor or sprinkler manufacturer regarding any questions.

It is recommended that automatic sprinkler systems be inspected, tested, and maintained by a qualified Inspection Service in accordance with local requirements and/or national codes.

TYPE	TEMP. RATING	BULB LIQUID	SPRINKLER FINISH (See Note 4)		
			NATURAL BRASS	CHROME PLATED	POLYESTER*
5.6K Conventional (TY365)	135°F (57°C)	Orange		1, 3, 4	
	155°F (68°C)	Red			
	175°F (79°C)	Yellow			
	200°F (93°C)	Green			
	286°F (141°C)	Blue			
	360°F (182°C)	Mauve			
5.6K Conventional (TY3650)	135°F (57°C)	Orange		2	
	155°F (68°C)	Red			
	175°F (79°C)	Yellow			
	200°F (93°C)	Green			
	286°F (141°C)	Blue			
	360°F (182°C)	Mauve			

NOTES:

- Listed by Underwriters Laboratories, Inc. (UL).
- Approved by the Loss Prevention Certification Board (LPCB Ref. No. 094a/05 & 007k/03).
- VdS Approved (For details contact Johnson Controls, Enschede, Netherlands, Tel. 310530428-4444/Fax 31-53-428-3377)
- Where Polyester Coated Sprinklers are noted to be UL Listed, the sprinklers are UL Listed as Corrosion Resistant Sprinklers.
* Frame and Deflector only.

TABLE A
LABORATORY LISTINGS AND APPROVALS

P/N* 77 - XXX - X - XXX

		SIN	SPRINKLER FINISH	TEMPERATURE RATINGS	
573	5.6K CONVENTIONAL (1/2 in. NPT)	TY365	1	NATURAL BRASS	135 135°F (57°C)
573	5.6K CONVENTIONAL	TY3650**	3	PURE WHITE (RAL9010)*** POLYESTER	155 155°F (68°C)
			4	SIGNAL WHITE (RAL9003) POLYESTER	175 175°F (79°C)
			9	CHROME PLATED	200 200°F (93°C)
					286 286°F (141°C)
					360 360°F (182°C)

* Use suffix "I" for ISO 7-1 connection; for example, 77-573-4-175-I
 ** LPCB approved Series TY-B Conventional Sprinkler assemblies only; Use suffix "L" for LPCB Approved assemblies (e.g., 77-573-4-175-L or 77-573-4-175-IL for LPCB Approved and ISO 7-1 connection)
 ***Eastern Hemisphere sales only

TABLE B
PART NUMBER SELECTION
SERIES TY-B CONVENTIONAL SPRINKLERS

Limited Warranty

For warranty terms and conditions, visit www.tyco-fire.com.

Ordering Procedure

Contact your local distributor for availability. When placing an order, indicate the full product name.

Sprinkler Assemblies with NPT Thread Connections

Specify: Series TY-B Conventional Sprinklers, SIN TY365, K=5.6, Standard Response, (specify) temperature rating, (specify) finish, P/N (specify, refer to Table B)

Sprinkler Wrench

Specify: W-Type 6 Sprinkler Wrench, P/N 56-000-6-387

